

# Gas Filter Separators



## Overview

A work horse of the gas industry, the Filter Separator is one of the most widely used filtration devices on the market. Introduced over 50 years ago, it has become the equipment of choice to purify natural gas and protect your capital investment, such as:

- Amine plants
- Glycol dehydrators
- Natural gas compressors
- Refrigeration plants
- Metering stations
- Gas storage facilities



The function of a Filter Separator is to remove fine to medium sized solid contaminant and entrained liquid from natural gas stream. Typical contaminant targeted by Filter Separators includes:

- High and medium surface tension liquids such as water and hydrocarbons.
- Non shear-sensitive solids such as sand, corrosion compounds and abrasives.
- Sticky and fouling contaminant such as waxes and asphaltenes.
- Pipeline and plant chemicals<sup>1</sup>.

<sup>1</sup>Consult your JCI Filtration & Separation specialist for element compatibility.

<sup>2</sup>Special elements for shear sensitive solids are available - consult factory.

The versatility of the filter separator is characterized through its high dirt holding capacity and excellent liquid handling capability.

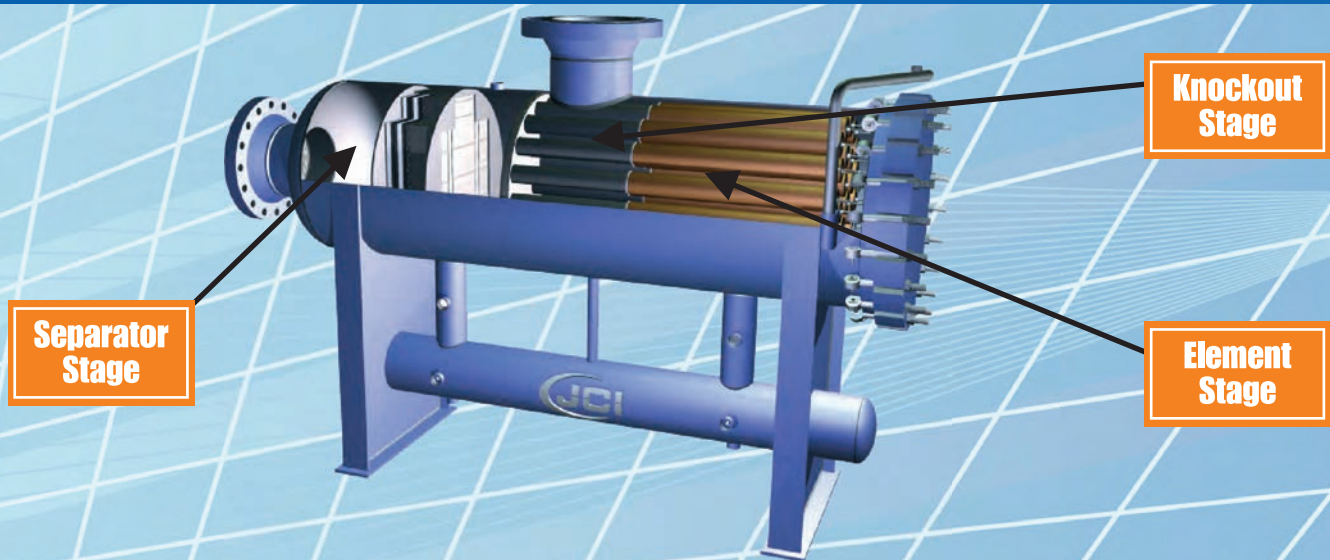

Often confused with a Reverse Flow Coalescer or a Separator, its design consists of three stages of filtration and separation: the knockout stage, the element stage and the separator stage. The element and separator stages are housed in separate compartments.

## Knockout Stage

As natural gas enters the Filter Separator, it impinges on element support posts, also known as risers. A correct length of the risers is crucial in preventing direct gas impingement on the elements. Gas impingement on the risers is used to disengage any heavier contaminant from the gas stream via impaction, deflection and gravity. In order to maximize deflection and make the most of gravity separation, JCI Filter Separators utilize a special optimized riser layout.

## Element Stage

In the standard offering the element stage of the Filter Separator is fitted with Jonell depth style cartridges made from varying bonded media. The direction of flow is outside to in for highest solids removal capacity. The elements also serve the function of coalescing small liquid droplets. The pre-coalesced droplets are now ready to be removed from the gas stream in the final separator stage. Element change-out is performed based on a pre-determined interval or differential pressure.

## Separator Stage

Depending on the nature of contaminant, the separator stage can be fitted with one of three available separation devices:

- A wire mesh mist eliminator
- A vane pack or mesh-vane assembly
- A centrifugal device

## Wire Mesh Mist Eliminator

For maximum performance, two JCI knitted mesh pads of varying density and thickness are fitted into the second compartment. Typical materials are various grades of stainless steel. Non-standard materials are also available for special applications. Low pressure drop and cost effectiveness are two of the benefits of using wire mesh. Wire mesh is not recommended for sticky fouling contaminant or for highly corrosive service.

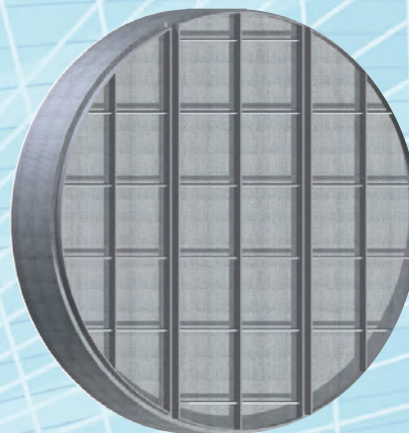

## Vane Mist Eliminator

JCI vane packs are custom engineered to meet process requirements. A multitude of specially shaped plates creates a tortuous path for the gas to pass through. Typical materials are various grades of stainless steel with a carbon steel enclosure. Low pressure drop, compact design and longevity are some of the benefits of using a vane pack in the final stage of a Filter Separator. The use of a vane pack should be limited where sticky and fouling contaminant is expected.

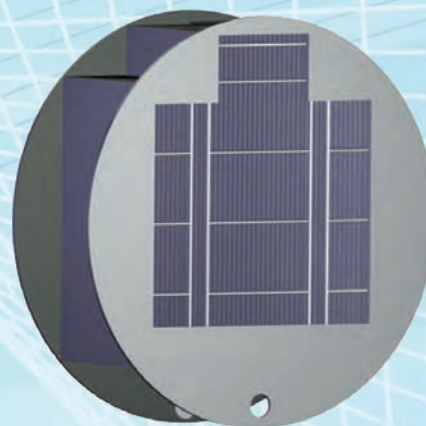

## Centrifugal Mist Eliminator

A Jonell cyclonic device called the Alta-Tube™ is recommended for severe, fouling service with high liquid loads. This type of device induces a spinning motion on the entering gas resulting in the ejection of contaminant via centrifugal force. The design of Alta-Tube™ ensures a continuous recirculation of gas, which prevents plugging and promotes self-cleaning. These cyclonic tubes are typically used in multiples determined by operating conditions. Carbon steel is the standard material with other materials also available. The Alta-Tube™ is the most versatile separation device on the market and can be fitted into a Filter Separator for almost any application.

## Horizontal Filter Separator

A horizontal Filter Separator is fitted with two separate liquid collection chambers. Depending on client preference and liquid loading, each unit can be built with a single horizontal sump or two vertical liquid collection boots. A horizontal sump is separated with a baffle plate into two independent chambers. Each liquid boot or horizontal chamber is sized proportionally to the upper barrel as well as expected liquid loading. Two stages of controls (manual or automated) are required for liquid monitoring and drainage.

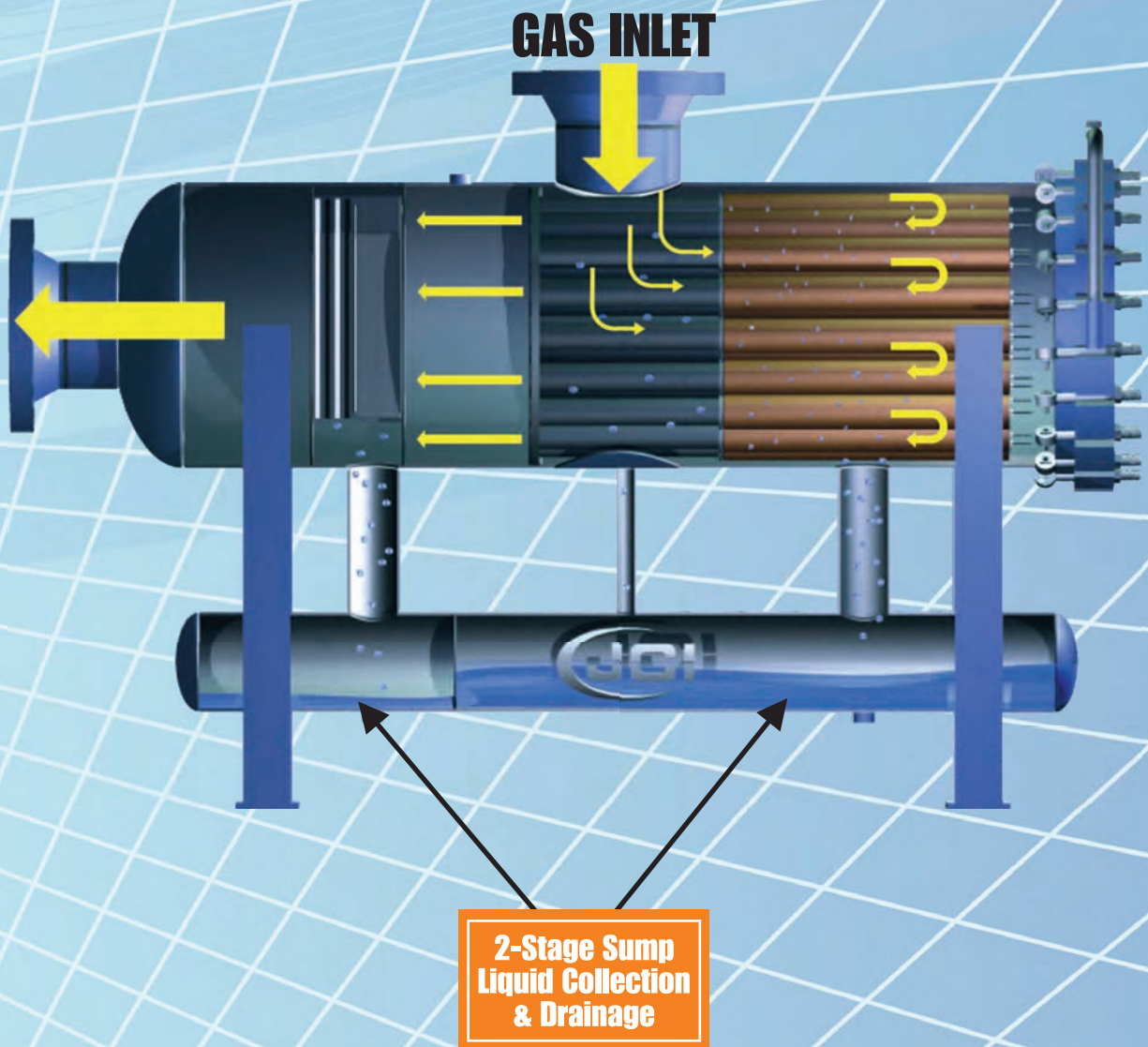

A correctly designed Filter Separator should achieve a maximum turn down of 10:1 and maintain a minimum efficiency of 98% of 1 micron throughout the entire range of operating conditions. Drainage and control of liquids is crucial to achieving this efficiency.

## Vertical Filter Separator

A vertical Filter Separator is designed with a top to bottom flow configuration and is most commonly designed with a vane pack or mesh-vane separator stage. This design also necessitates two liquid collection chambers. Any liquid knocked out in the first stage, or upper chamber, is collected and drained off to a common drain header. The second stage, or lower chamber, retains liquids that have been removed from gas stream by the vane pack.

## Common Attributes

A number of other crucial design aspects include element flow capacity, nozzle velocities, bulk and annular velocities, element spacing, nozzle positioning, gas contact area in the separator stage, pressure drop and flux rates. When you purchase a JCI Filter Separator you can rest easy knowing that all requirements of process design have been considered to ensure maximum performance.

**Upper & Lower  
Compartment  
Liquid Collection  
& Drainage**

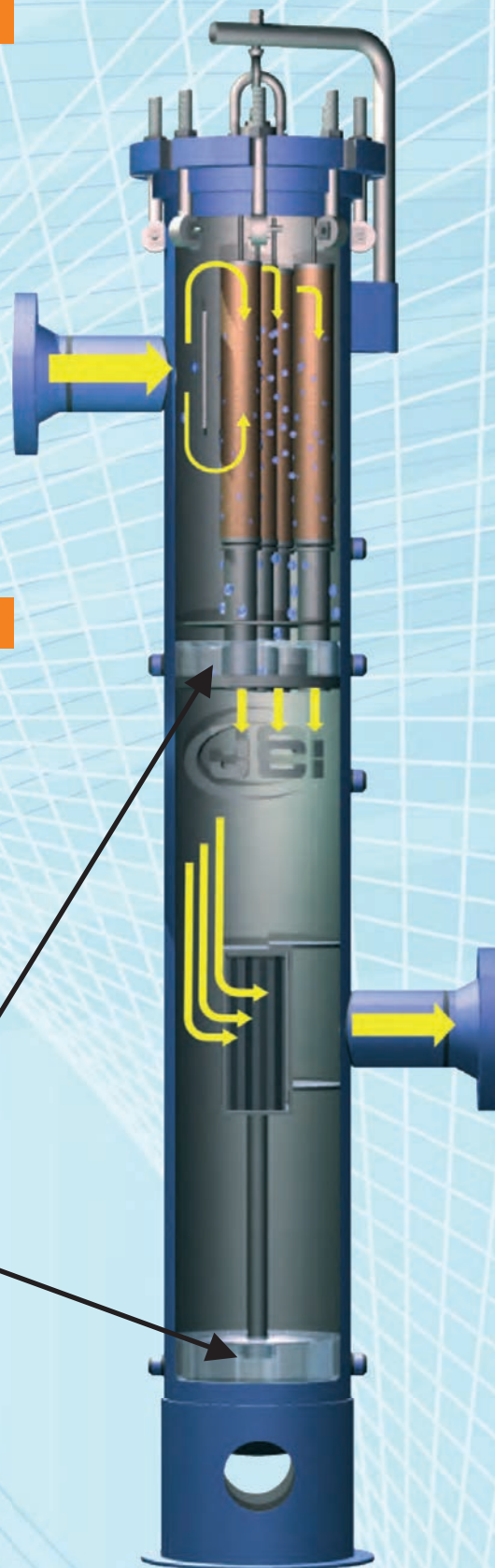

## Element Selection

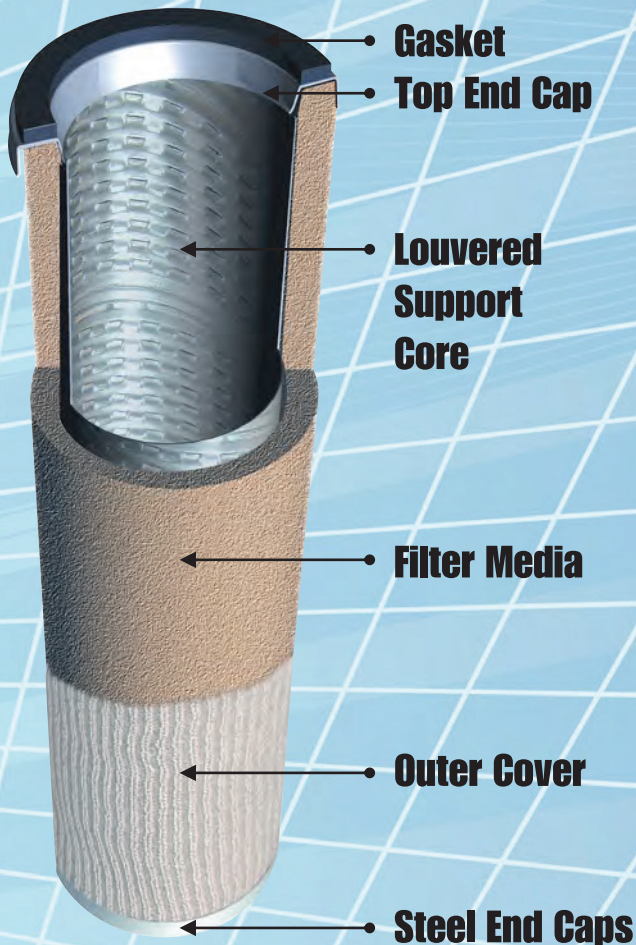

**Jonell Standard Element Construction:**  
Molded fiberglass media designed to efficiently coalesce liquids while delivering high solids loading capacity. Plated steel end caps and cores, joined mechanically to ensure high integrity of the element. A cotton outer cover to protect the element and the operator during installation.

**Jonell Standard Element Construction:**  
Patented Tri-DEP™ Polyester or Polypropylene media made from trilobal shape fibers for greater contaminant loading and increased filter life cycle, with inner and outer cage for maximum durability.

Jonell filter separator elements are available in various standard and custom sizes to fit virtually every application, as well as cross-over. They are engineered and manufactured in standard fiberglass, micro-glass and polymeric media to ensure compatibility with any process.

### JFG SERIES

Material of Construction	Fiberglass
Maximum Temperature	275°F
Minimum Temperature	60°F
Change Out Differential	15 PSID
Burst Pressure	>75 PSID
Available Micron Rating	1, 5, 10
Standard Sizes	312, 324, 336, 372, 536

### JMG SERIES

Material of Construction	Micro-Glass
Maximum Temperature	275°F
Minimum Temperature	60°F
Change Out Differential	15 PSID
Burst Pressure	>75 PSID
Available Micron Rating	0.3, 0.5, 1, 5, 10
Standard Sizes	312, 324, 336, 372, 536

### JEB SERIES

Material of Construction	Polyester
Maximum Temperature	240°F
Minimum Temperature	60°F
Change Out Differential	15 PSID
Burst Pressure	>75 PSID
Available Micron Rating	0.3, 0.5, 1, 5, 10
Standard Sizes	312, 324, 336, 372, 536

## Vessel Nomenclature

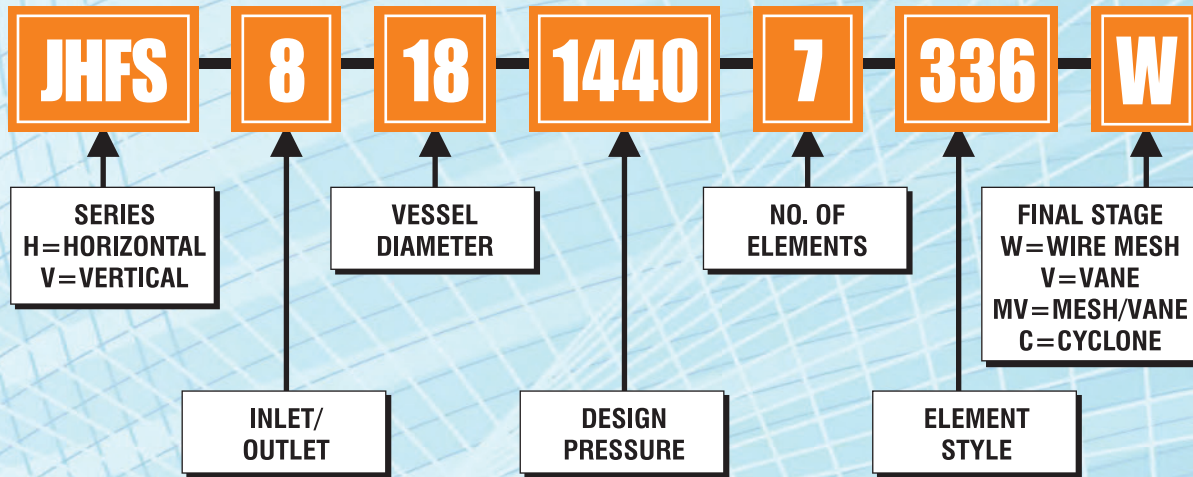

## Inquiry Information

As a minimum, the following information is required for all Filter Separator sizing and pricing inquiries:

- Gas Volumetric Flow Rate
- Gas specific gravity, molecular weight or composition
- Gas operating pressure range
- Gas operating temperature range
- Type of contaminant to be filtered
- Amount of free and entrained liquid
- Vessel design conditions, including pressure, temperature and corrosion allowance

### Contact Information:

Tel 403.313.1559

Fax 403.280.7926

[sales@jci-group.com](mailto:sales@jci-group.com)

[www.jci-fs.com](http://www.jci-fs.com)



JCI Filtration & Separation Inc.

JCI and the JCI logo are trademarks of JCI Holdings Ltd., used under license by JCI Filtration & Separation Inc.